

## Guidance for packing desktop equipment

# NOTEBOOKS

You will need;

- A pallet or pallets
- Cardboard or plastic notebook packing boxes
- Cardboard sheets
- Bubble wrap sleeves or sheets
- Packing tape
- Plastic wrap

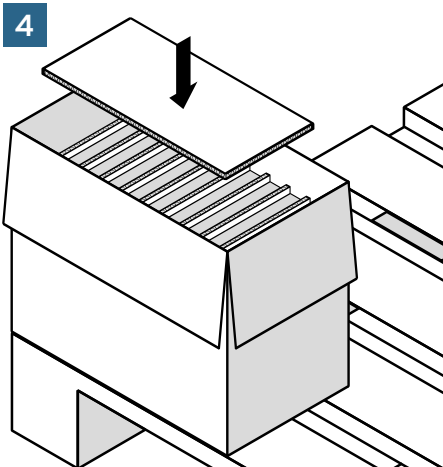
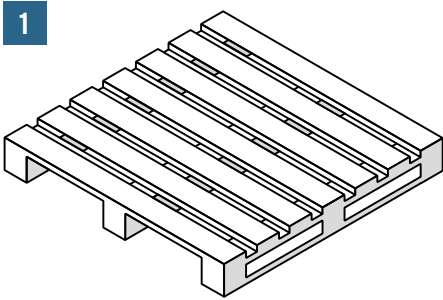

■ Leave spaces at the sides of the box for extra protection. Place cardboard sheet over the top.

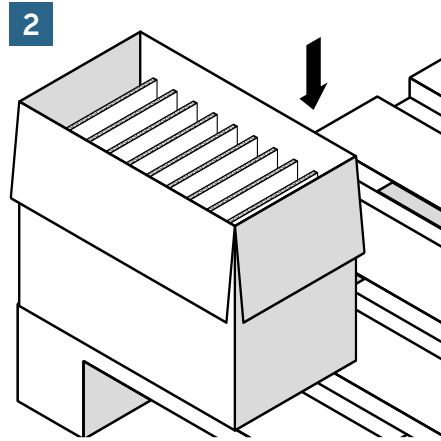
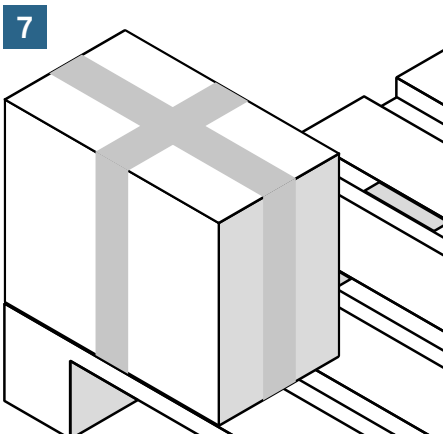

■ Place your first layer of boxes on your pallet. Cardboard boxes contain cardboard sheets to separate the notebooks.

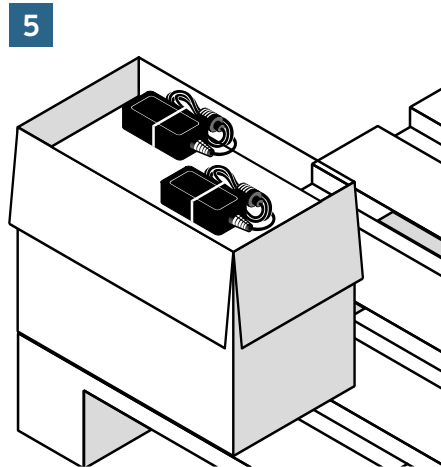

■ Place AC adaptors on top of cardboard sheet. Secure AC adaptors with tie wraps or bands.

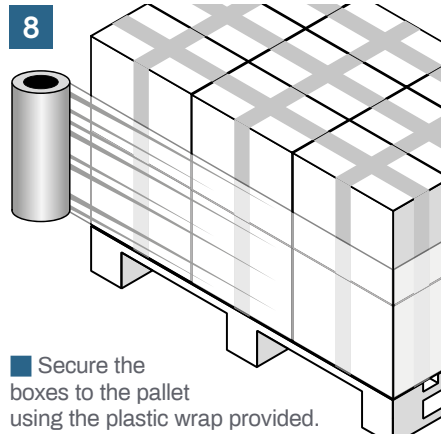

■ Secure the boxes to the pallet using the plastic wrap provided.

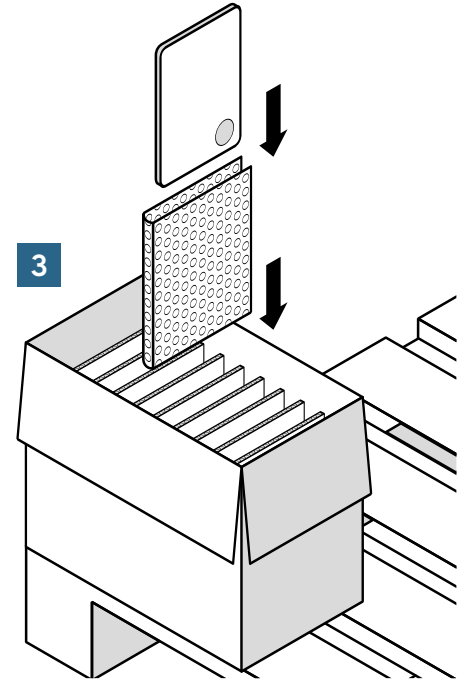

■ Wrap each laptop in bubble wrap. This helps to avoid scratching in transit! Cardboard notebook boxes take 10 notebooks per box. Plastic boxes take 12 notebooks per box.

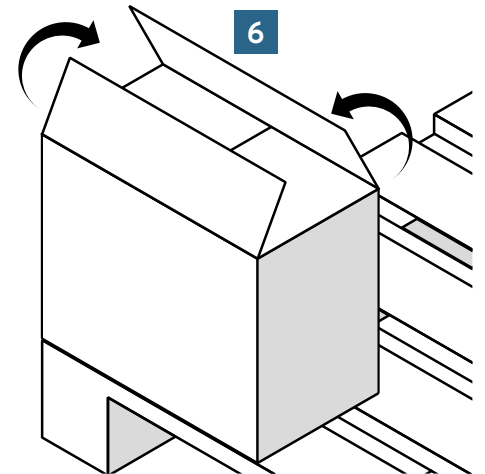

■ Close your box and seal with tape.

■ Cardboard boxes can be stacked up to 3 high on pallet.

■ Plastic boxes can be stacked up to 2 high on pallet.

**When possible please reuse or recycle packaging materials**

[simsrecycling.com/reuse/logistics](https://simsrecycling.com/reuse/logistics)

Now all you need to do is label your pallet and book a collection!

Packing something different? Contact your SLS representative for more advice.